

STEELMAN

INDUSTRIAL QUALITY OVENS CATALOG

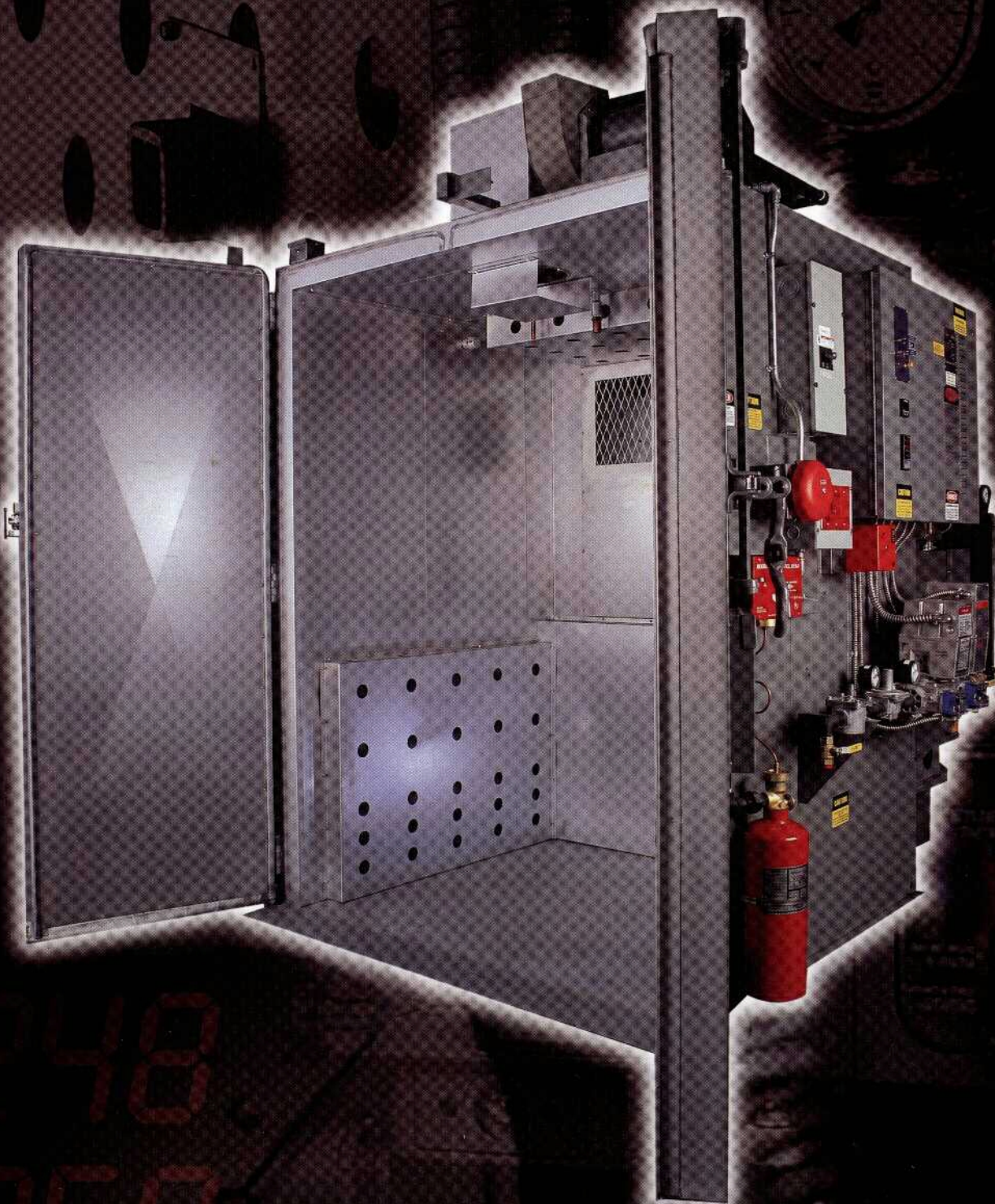

1-888-735-8831

STANDARD - DOUBLE DOORS ON ONE END ONLY 500°F

TOP VIEW (w/ Doors)

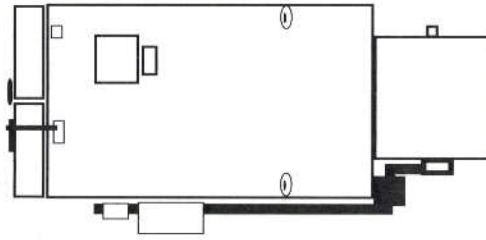

FRONT VIEW (wo/ Doors)

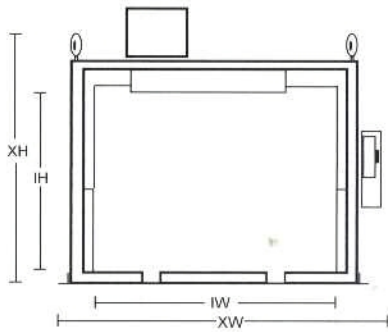

SIDE VIEW (w/ Doors)

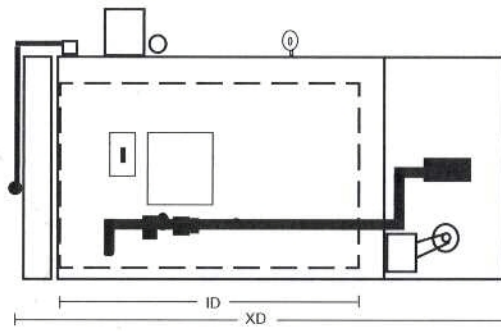

OPTIONAL - DOUBLE DOORS BOTH ENDS 500°F

TOP VIEW (w/ Doors)

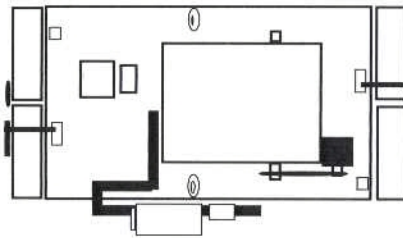

FRONT VIEW (wo/ Doors)

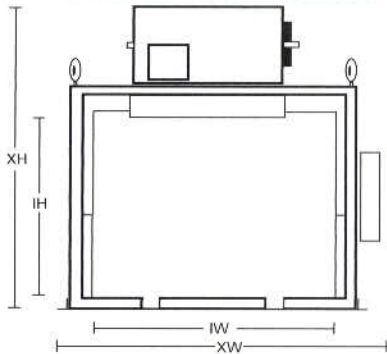

SIDE VIEW (w/ Doors)

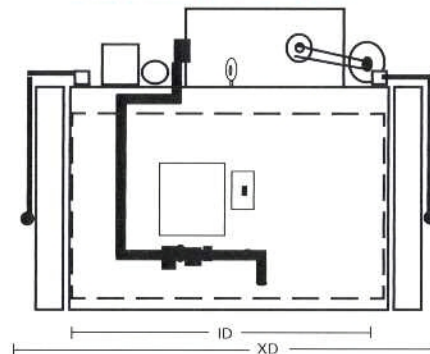

DIMENSIONS & WEIGHTS - 500°F DESIGN

Model Number (WHD)	Interior Dimension (IW x IH x ID)	Volume Inside (Ft³)	STANDARD DOORS ON ONE END				OPTION DOORS ON BOTH ENDS(DE)			
			Exterior Dimension ** (XW x XH x XD)			Approx** Wgt(lbs)	Exterior Dimension ** (XW x XH x XD)			Approx** Wgt(lbs)
242	2' 4" 2'	16	3' 6"	5' 4"	4' 6"	1,000	N/A	N/A	N/A	N/A
333	3' 3" 3'	27	5' 2"	5' 2"	6' 2"	1,700	N/A	N/A	N/A	N/A
343	3' 4" 3'	36	5' 2"	6' 2"	6' 2"	1,850	N/A	N/A	N/A	N/A
353	3' 5" 3'	45	5' 2"	6' 6"	6' 2"	2,000	N/A	N/A	N/A	N/A
444	4' 4" 4'	64	6' 2"	6' 2"	7' 6"	2,600	6' 2"	7' 2"	5' 4"	2,700
446	4' 4" 6'	96	6' 2"	6' 2"	9' 6"	3,800	6' 2"	7' 2"	7' 4"	3,900
454	4' 5" 4'	80	6' 2"	6' 6"	7' 6"	3,000	6' 2"	8' 2"	5' 4"	3,100
455	4' 5" 5'	100	6' 2"	6' 6"	8' 6"	3,600	6' 2"	8' 2"	6' 4"	3,700
464	4' 6" 4'	96	6' 2"	7' 6"	7' 6"	3,800	6' 2"	9' 2"	5' 4"	3,900
466	4' 6" 6'	144	6' 2"	7' 6"	9' 6"	4,200	6' 2"	9' 7"	7' 4"	4,350
484	4' 8" 4'	128	6' 2"	9' 6"	7' 6"	4,000	6' 2"	11' 7"	5' 4"	4,150
555	5' 5" 5'	125	7' 2"	6' 6"	8' 6"	3,900	7' 2"	8' 7"	6' 4"	4,050
565	5' 6" 5'	150	7' 2"	7' 6"	8' 6"	4,200	7' 2"	9' 7"	6' 4"	4,400
566	5' 6" 6'	180	7' 2"	7' 6"	9' 6"	4,500	7' 2"	9' 7"	7' 4"	4,600
567	5' 6" 7'	210	7' 2"	7' 6"	10' 6"	4,800	7' 2"	9' 7"	8' 4"	4,950
568	5' 6" 8'	240	7' 2"	7' 6"	11' 6"	5,000	7' 2"	9' 7"	9' 4"	5,150
5610	5' 6" 10'	300	7' 4"	7' 6"	14' 0"	5,400	7' 4"	9' 9"	11' 4"	5,600
5612	5' 6" 12'	360	7' 4"	7' 6"	16' 0"	5,700	7' 4"	9' 9"	13' 4"	5,900
666	6' 6" 6'	216	8' 2"	7' 6"	9' 6"	4,900	8' 2"	9' 7"	7' 4"	5,050
668	6' 6" 8'	288	8' 4"	7' 6"	12' 0"	5,500	8' 4"	9' 9"	9' 4"	5,650
6610	6' 6" 10'	360	8' 4"	7' 6"	14' 0"	6,000	8' 4"	9' 9"	11' 4"	6,200
676	6' 7" 6'	252	8' 2"	8' 6"	9' 6"	5,200	8' 2"	10' 7"	7' 4"	5,350
677	6' 7" 7'	294	8' 4"	8' 6"	11' 0"	5,600	8' 4"	10' 9"	8' 4"	5,750
678	6' 7" 8'	336	8' 4"	8' 6"	12' 0"	6,000	8' 4"	10' 9"	9' 4"	6,200
6710	6' 7" 10'	420	8' 4"	8' 6"	14' 0"	6,800	8' 4"	10' 9"	11' 4"	7,000
6712	6' 7" 12'	504	8' 4"	8' 6"	16' 0"	7,500	8' 4"	10' 9"	13' 4"	7,700
6714	6' 7" 14'	588	8' 4"	8' 6"	18' 0"	8,000	8' 4"	10' 9"	15' 4"	8,200
6716	6' 7" 16'	672	8' 4"	8' 6"	20' 0"	8,400	8' 4"	10' 9"	17' 4"	8,600
6720	6' 7" 20'	840	8' 4"	8' 6"	24' 0"	8,800	8' 4"	10' 9"	21' 4"	9,000
686	6' 8" 6'	288	8' 4"	9' 6"	10' 0"	5,500	8' 4"	11' 9"	7' 4"	5,650
688	6' 8" 8'	384	8' 4"	9' 6"	12' 0"	6,500	8' 4"	11' 9"	9' 4"	6,700
777	7' 7" 7'	343	9' 4"	8' 6"	11' 0"	6,300	9' 4"	10' 9"	8' 4"	6,500
778	7' 7" 8'	392	9' 4"	8' 6"	12' 0"	6,700	9' 4"	10' 9"	9' 4"	6,950
7710	7' 7" 10'	490	9' 4"	8' 6"	14' 0"	7,400	9' 4"	10' 9"	11' 4"	7,650
7712	7' 7" 12'	588	9' 4"	8' 6"	16' 0"	7,800	9' 4"	10' 9"	13' 4"	8,050
7714	7' 7" 14'	686	9' 4"	8' 6"	18' 0"	8,300	9' 4"	10' 9"	15' 4"	8,550
7716	7' 7" 16'	784	9' 4"	8' 6"	20' 0"	8,800	9' 4"	10' 9"	17' 4"	9,050
7720	7' 7" 20'	980	9' 4"	8' 6"	24' 7"	9,300	9' 4"	11' 1"	21' 4"	9,600
787	7' 8" 7'	392	9' 4"	9' 6"	11' 0"	6,700	9' 4"	11' 9"	8' 4"	6,950
788	7' 8" 8'	448	9' 4"	9' 6"	12' 0"	7,200	9' 4"	11' 9"	9' 4"	7,400
888	8' 8" 8'	512	10' 4"	9' 6"	12' 0"	7,400	10' 4"	11' 9"	9' 4"	7,650
8810	8' 8" 10'	640	10' 4"	9' 6"	14' 0"	8,000	10' 4"	11' 9"	11' 4"	8,250
8812	8' 8" 12'	768	10' 4"	9' 6"	16' 0"	8,600	10' 4"	11' 9"	13' 4"	8,850
8814	8' 8" 14'	896	10' 4"	9' 6"	18' 7"	8,900	10' 4"	12' 1"	15' 4"	9,150
8816	8' 8" 16'	1,024	10' 4"	9' 6"	20' 7"	9,400	10' 4"	12' 1"	17' 4"	9,650
8820	8' 8" 20'	1,280	10' 8"	9' 6"	25' 1"	10,200	10' 8"	12' 7"	21' 4"	10,500
8108 ¹	8' 10' 8'	640	10' 4"	11' 6"	12' 0"	8,000	10' 4"	13' 9"	9' 4"	8,250
81010 ¹	8' 10' 10'	800	10' 4"	11' 6"	14' 0"	8,800	10' 4"	13' 9"	11' 4"	9,050
81012 ¹	8' 10' 12'	960	10' 4"	11' 6"	16' 7"	9,000	10' 4"	14' 1"	13' 4"	9,200
81014 ¹	8' 10' 14'	1,120	10' 4"	11' 6"	18' 7"	9,500	10' 4"	14' 1"	15' 4"	9,750
81016 ¹	8' 10' 16'	1,280	10' 8"	11' 6"	21' 1"	10,200	10' 8"	14' 7"	17' 4"	10,450
81020 ¹	8' 10' 20'	1,600	10' 8"	11' 6"	25' 1"	11,000	10' 8"	14' 7"	21' 4"	11,300
101010 ¹	10' 10' 10'	1,000	12' 4"	11' 6"	14' 7"	9,100	12' 4"	14' 1"	11' 4"	9,350
101012 ¹	10' 10' 12'	1,200	12' 4"	11' 6"	16' 7"	9,600	12' 4"	14' 1"	13' 4"	9,850
101014 ¹	10' 10' 14'	1,400	12' 8"	11' 6"	19' 1"	10,000	12' 8"	14' 7"	15' 4"	10,300
101016 ¹	10' 10' 16'	1,600	12' 8"	11' 6"	21' 1"	10,800	12' 8"	14' 7"	17' 4"	11,100
101020 ¹	10' 10' 20'	2,000	12' 8"	11' 6"	25' 11"	12,000	12' 8"	15' 5"	21' 4"	12,300
101210 ¹	10' 12' 10'	1,200	12' 4"	13' 6"	14' 7"	9,600	12' 4"	16' 1"	11' 4"	9,850
101212 ¹	10' 12' 12'	1,440	12' 8"	13' 6"	17' 1"	10,500	12' 8"	16' 7"	13' 4"	10,850
101214 ¹	10' 12' 14'	1,680	12' 8"	13' 6"	19' 1"	11,200	12' 8"	16' 7"	15' 4"	11,550
101216 ¹	10' 12' 16'	1,920	12' 8"	13' 6"	21' 11"	12,200	12' 8"	17' 5"	17' 4"	12,550
101220 ¹	10' 12' 20'	2,400	12' 8"	13' 6"	25' 11"	13,300	12' 8"	17' 5"	21' 4"	13,650
121212 ¹	12' 12' 12'	1,728	14' 8"	13' 6"	17' 1"	11,900	14' 8"	16' 7"	13' 4"	12,250
121214 ¹	12' 12' 14'	2,016	14' 8"	13' 6"	19' 11"	12,600	14' 8"	17' 5"	15' 4"	13,000
121216 ¹	12' 12' 16'	2,304	14' 8"	13' 6"	21' 11"	13,500	14' 8"	17' 5"	17' 4"	13,900
121220 ¹	12' 12' 20'	2,880	14' 8"	13' 6"	25' 11"	14,600	14' 8"	17' 5"	21' 4"	15,000

¹ Burner Box is built Removable Overhead if Option for Doors on Both Ends is Selected.
 ** Dimensions and Weights are Subject to Change without Notice. Contact Factory for Latest Specifications.

STEEL PLATE FLOOR OVENS

— ELECTRIC (ESP) GAS (GSP)

- Steel Plate Floor Ovens include 1/4" Plate with Beveled Edge for Easy Cart Movement
- Steel Plate Floor Ovens are available in types Electric or Gas (except model 242)
- Ideal when various types of loading are required (carts, lifts, baskets, etc.)



INSULATED FLOOR OVENS

— ELECTRIC (EIF) GAS (GIF)

- Insulated Floor Ovens are made of 14g steel on 3" Angle Iron w/ 8# density insulation
- Insulated Floor Ovens are available in types Electric or Gas (except model 242)
- These Ovens are Normally used in Overhead or Fork Lift Loading Applications

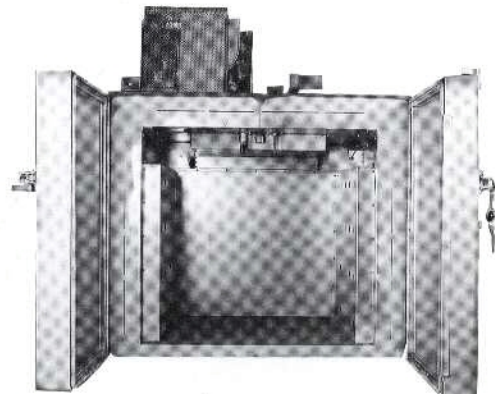

PORTABLE CART FLOOR OVENS

— ELECTRIC (EPC) GAS (GPC)

- Portable Cart Floors are Insulated and Slotted to Facilitate Loading Carts into the Ovens
- Portable Cart Floor Ovens are available in types Electric or Gas (Except model 242)
- Ideal when Oven is Loaded with the Same Cart or by Carts of Similar Wheel Centerlines



TRACK CART FLOOR OVENS

— ELECTRIC (ETC) GAS (GTC)

- Track Cart Floors are Insulated, Slotted and Include Inverted Angle Iron Tracks
- Track Cart Floor Ovens are available in types Electric or Gas (except model 242)
- These Ovens are Ideal for Handling Large and Heavy Loads



SPECIFICATIONS - 500°F DESIGN

Model Number (WHD)	CIRCULATION *			ELECTRIC SERVICE *				GAS SERVICE *				
	Rate (CFM)	Changes / Min.	Motor HP(#)	Utility (KW)	Exhaust (CFM)	Motor (HP)	240/480V (Disconnect)	Gas (BTU/k)	Gas Line Size	Exhaust (CFM)	Motor (HP)	240/480V (Disconnect)
242	700	43.7	1/3(1)	14.7	100	1/3	50 / 25	N/A	N/A	N/A	N/A	N/A
333	700	25.9	1/3(1)	18.0	100	1/3	60 / 30	200	1 1/4"	250	1/3	15 / 15
343	700	19.4	1/3(1)	29.4	100	1/3	100 / 50	200	1 1/4"	250	1/3	15 / 15
353	700	15.6	1/3(1)	29.4	100	1/3	100 / 50	200	1 1/4"	250	1/3	15 / 15
444	1,400	21.9	1/3(2)	36.0	250	1/3	125 / 60	250	1 1/4"	500	1/3	15 / 15
446	1,400	14.6	1/3(2)	44.1	250	1/3	140 / 30	250	1 1/4"	500	1/3	15 / 15
454	1,400	17.5	1/3(2)	36.0	250	1/3	125 / 60	250	1 1/4"	500	1/3	15 / 15
455	1,400	14.0	1/3(2)	44.1	250	1/3	140 / 70	250	1 1/4"	500	1/3	15 / 15
464	1,400	14.6	1/3(2)	44.1	250	1/3	140 / 70	250	1 1/4"	500	1/3	15 / 15
466	3,200	22.2	3/4(2)	44.1	250	1/3	140 / 70	300	1 1/4"	500	1/3	15 / 15
484	3,200	25.0	3/4(2)	44.1	250	1/3	140 / 70	300	1 1/4"	500	1/3	15 / 15
555	3,200	25.6	3/4(2)	44.1	250	1/3	140 / 70	300	1 1/4"	500	1/3	15 / 15
565	3,200	21.3	3/4(2)	44.1	250	1/3	140 / 70	300	1 1/4"	500	1/3	15 / 15
566	3,200	17.8	3/4(2)	44.1	250	1/3	140 / 70	300	1 1/4"	500	1/3	15 / 15
567	3,200	15.2	3/4(2)	58.8	250	1/3	190 / 100	300	1 1/4"	500	1/3	15 / 15
568	3,200	13.3	3/4(2)	58.8	250	1/3	190 / 100	300	1 1/4"	500	1/3	15 / 15
5610	4,000	13.3	5(1)	73.5	500	3/4	250 / 125	300	1 1/4"	500	3/4	25 / 15
5612	5,000	13.9	5(1)	73.5	500	3/4	250 / 125	350	1 1/4"	500	3/4	25 / 15
666	3,200	14.8	3/4(2)	58.8	250	1/3	200 / 100	300	1 1/4"	500	1/3	15 / 15
668	4,000	13.9	5(1)	58.8	500	3/4	200 / 100	350	1 1/4"	500	3/4	25 / 15
6610	5,000	13.9	5(1)	73.5	500	3/4	250 / 125	350	1 1/4"	500	3/4	25 / 15
676	3,200	12.7	3/4(2)	58.8	250	1/3	200 / 100	300	1 1/4"	500	1/3	15 / 15
677	4,000	13.6	5(1)	73.5	500	3/4	250 / 125	350	1 1/4"	500	3/4	25 / 15
678	4,000	11.9	5(1)	73.5	500	3/4	250 / 125	400	1 1/4"	500	3/4	25 / 15
6710	5,000	11.9	5(1)	73.5	500	3/4	250 / 125	400	1 1/4"	500	3/4	25 / 15
6712	6,000	11.9	7.5(1)	88.2	500	3/4	300 / 150	400	1 1/4"	500	3/4	35 / 20
6714	7,000	11.9	7.5(1)	88.2	500	3/4	300 / 150	500	1 1/4"	500	3/4	35 / 20
6716	8,000	11.9	7.5(1)	102.9	500	3/4	350 / 175	600	1 1/4"	500	3/4	35 / 20
6720	10,000	11.9	10(1)	147.0	750	3/4	500 / 250	600	1 1/4"	750	3/4	40 / 20
686	4,000	13.9	5(1)	58.8	500	3/4	200 / 100	300	1 1/4"	500	3/4	25 / 15
688	5,000	13.0	5(1)	73.5	500	3/4	250 / 125	350	1 1/4"	500	3/4	25 / 15
777	4,000	11.7	5(1)	73.5	500	3/4	250 / 125	350	1 1/4"	500	3/4	25 / 15
778	5,000	12.8	5(1)	73.5	500	3/4	250 / 125	350	1 1/4"	500	3/4	25 / 15
7710	6,000	12.2	7.5(1)	88.2	500	3/4	300 / 150	400	1 1/4"	500	3/4	35 / 20
7712	7,000	11.9	7.5(1)	88.2	500	3/4	300 / 150	500	1 1/4"	500	3/4	35 / 20
7714	8,000	11.7	7.5(1)	102.9	500	3/4	350 / 175	600	1 1/4"	500	3/4	35 / 20
7716	10,000	12.8	10(1)	147.0	750	3/4	500 / 250	600	1 1/4"	750	3/4	40 / 20
7720	12,000	12.2	10(1)	176.4	1,000	3/4	600 / 300	700	1 1/4"	1,000	3/4	40 / 20
787	5,000	12.8	5(1)	73.5	500	3/4	250 / 125	350	1 1/4"	500	3/4	25 / 15
788	5,000	11.2	5(1)	73.5	500	3/4	250 / 125	500	1 1/4"	500	3/4	25 / 15
888	6,000	11.7	7.5(1)	88.2	500	3/4	300 / 150	500	1 1/4"	500	3/4	35 / 20
8810	8,000	12.5	7.5(1)	102.9	500	3/4	350 / 175	500	1 1/4"	500	3/4	35 / 20
8812	9,000	11.7	10(1)	147.0	500	3/4	500 / 250	600	1 1/4"	500	3/4	40 / 20
8814	11,000	12.3	10(1)	176.4	750	3/4	600 / 300	700	1 1/4"	750	3/4	40 / 20
8816	12,000	11.7	10(1)	176.4	1,000	3/4	600 / 300	800	1 1/4"	1,000	3/4	40 / 20
8820	16,000	12.5	15(1)	205.8	1,350	1	700 / 350	1,000	1 1/4"	1,350	1	60 / 30
8108	8,000	12.5	7.5(1)	102.9	500	3/4	350 / 175	500	1 1/4"	500	3/4	35 / 20
81010	10,000	12.5	10(1)	176.4	750	3/4	600 / 300	700	1 1/4"	750	3/4	40 / 20
81012	12,000	12.5	10(1)	176.4	1,000	3/4	600 / 300	700	1 1/4"	1,000	3/4	40 / 20
81014	14,000	12.5	15(1)	205.8	1,000	3/4	700 / 350	900	1 1/4"	1,000	3/4	60 / 30
81016	16,000	12.5	15(1)	205.8	1,000	3/4	700 / 350	1,000	1 1/4"	1,000	3/4	60 / 30
81020	19,000	11.9	15(1)	N/A	N/A	N/A	N/A	1,200	1 1/4"	1,350	1	60 / 30
101010	12,000	12.0	10(1)	176.4	1,000	3/4	600 / 300	800	1 1/4"	1,000	3/4	40 / 20
101012	14,000	11.7	15(1)	205.8	1,000	3/4	700 / 350	900	1 1/4"	1,000	3/4	60 / 30
101014	17,000	12.1	15(1)	235.2	1,000	3/4	800 / 400	1,000	1 1/4"	1,000	3/4	60 / 30
101016	19,000	11.9	15(1)	N/A	N/A	N/A	N/A	1,200	1 1/4"	1,350	1	60 / 30
101020	24,000	12.0	20(1)	N/A	N/A	N/A	N/A	1,500	1 1/4"	1,500	1	80 / 40
101210	14,000	11.7	15(1)	205.8	1,000	3/4	700 / 350	900	1 1/4"	1,000	3/4	60 / 30
101212	18,000	12.5	15(1)	235.2	1,350	1	800 / 400	1,000	1 1/4"	1,350	1	60 / 30
101214	20,000	11.9	15(1)	N/A	N/A	N/A	N/A	1,200	1 1/4"	1,500	1	60 / 30
101216	24,000	12.5	20(1)	N/A	N/A	N/A	N/A	1,400	1 1/4"	1,500	1	80 / 40
101220	28,000	11.7	25(1)	N/A	N/A	N/A	N/A	1,800	1 1/4"	2,000	2	100 / 50
121212	22,000	12.7	20(1)	N/A	N/A	N/A	N/A	1,300	1 1/4"	1,500	1	80 / 40
121214	24,000	11.9	20(1)	N/A	N/A	N/A	N/A	1,500	1 1/4"	1,500	1	80 / 40
121216	28,000	12.2	25(1)	N/A	N/A	N/A	N/A	1,700	1 1/4"	2,000	2	100 / 50
121220	34,000	11.8	30(1)	N/A	N/A	N/A	N/A	2,200	1 1/4"	2,000	2	110 / 60

* Specifications are Subject to Change without Notice. Contact Factory for Latest Specifications.

DOUBLE DOORS ON EACH END — (OPTION - DE)

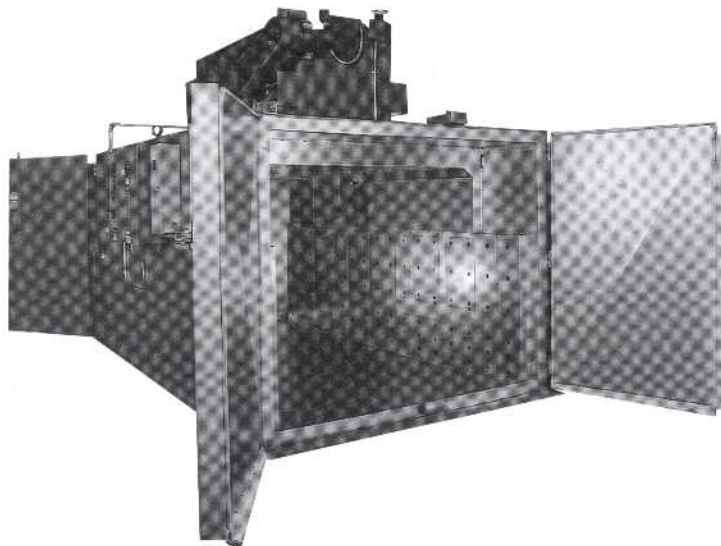

- This Option Allows Loading from Both Ends and/or Passage of Material through Oven
- Double Doors on Each End are Available in all Sizes except 242, 333, 343 & 353
- Double Doors on Each End are Available in all Floor Styles
- Double Doors on Each End can not be Used with the Chain Hoist Loading Door Option
- Double Doors on Each End can be Used with the Option for Overhead Rail Accommodation

CHAIN HOIST LOADING DOOR — (OPTION - CHLD)

- 4" Wide Door in Top of Oven to Allow the Passage of a Hoist into the Oven
- The Length of Door ends at Half of the Interior Depth of the Oven
- The Chain Hoist Loading Door is Available in all Floor Styles
- The Chain Hoist Loading Door is Available in most Oven Sizes
- The Chain Hoist Loading Door cannot be used with Vertical Lift Doors or Doors on Each End

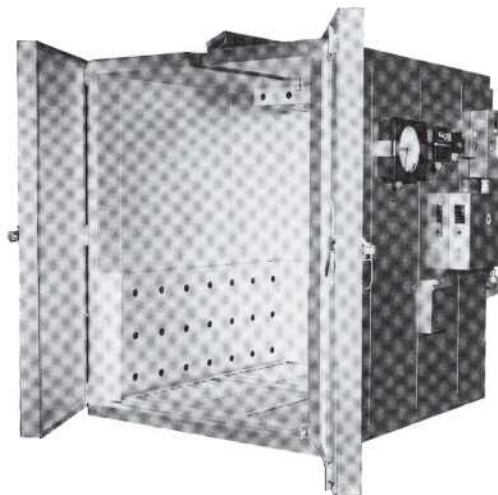

VERTICAL LIFT DOOR — (OPTION - VD)

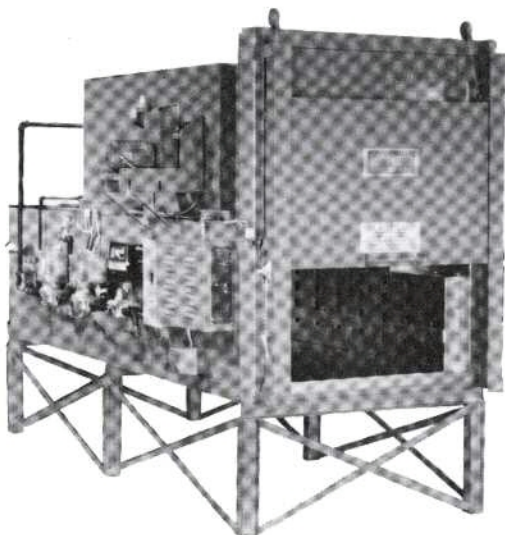

- Vertical Lift Doors are Available in Lieu of Swing Type Doors
- Vertical Doors are Available in Types: Mechanical, Counter Balanced, Motor Drive, or Pneumatic
- The Vertical Lift Door Option is Available in all Floor Styles
- The Vertical Lift Door Option is Available in most Oven Sizes
- The Vertical Lift Door Option is not Available with the Chain Hoist Loading Door Option

OVERHEAD RAIL ACCOMMODATIONS



(OPTION - R1, R2 or R3)

- 2" x 2" Square Tubing Drop Downs are Built into the Oven Frame To Which Overhead Rails can be Attached
- Doors are specially Constructed to Swing Around Rail Location (R1)
- A Transom with 4" x 4" Cutouts Allows for Rail Entrance and Exit Above Doors (R2, R3, ...)
- Rails are Normally Supplied and Attached by Customer
- Customer to Specify Number and Location of Rail Accommodations

SINGLE OVERHEAD RAIL ACCOMMODATION — (OPTION R1)

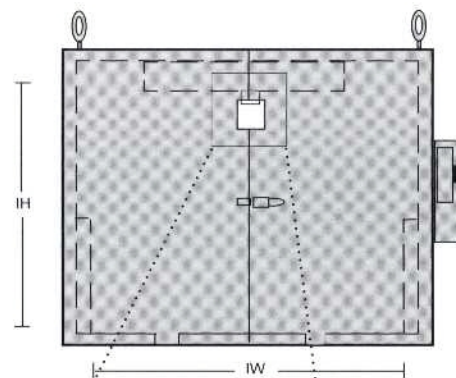
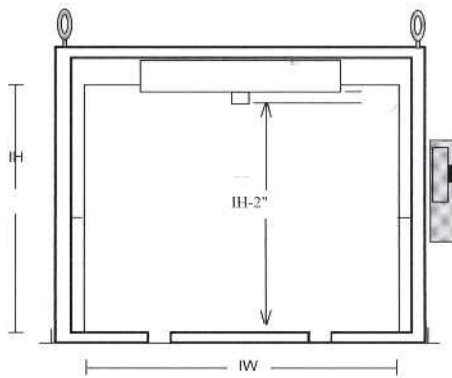

Drop Down to Which Rail can be Attached

Opening in Doors for Rail

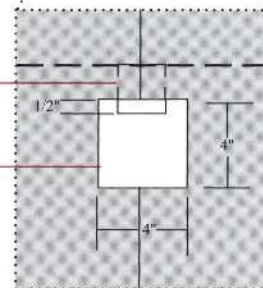

DUAL OVERHEAD RAIL ACCOMMODATION — (OPTION R2)

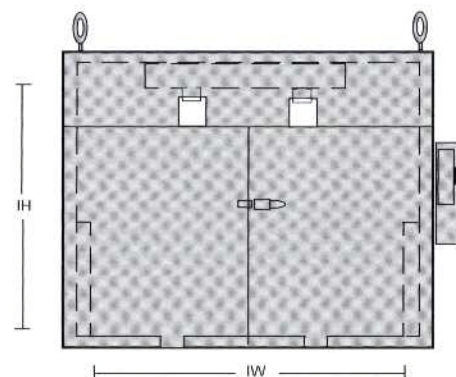
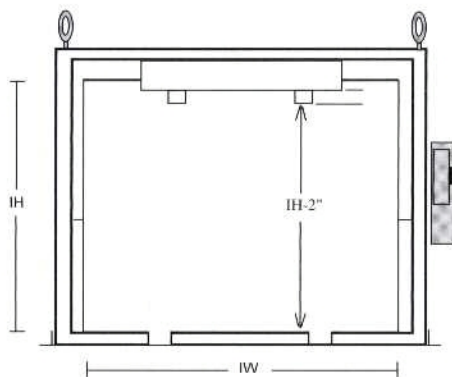

DIMENSIONS & SPECIFICATIONS - 500°F DESIGN

Model Number (WHD)	Bench or Cabinet (B or C)	Interior Dimension (IW x IH x ID)			Work Height* (WH)	Volume Inside (Ft³)	Exterior Dimension* (XW x XH x XD)			Approx. Weight* (lbs)	Electric Power* (KW)	Disconnect* 240V/480V (Amperage)
222	B	2'	2'	2'	3"	8	3' 6"	3' 0"	4' 0"	500	9.0	30 / 15
232	B	2'	3'	2'	3"	12	3' 6"	4' 0"	4' 0"	750	9.0	30 / 15
242	B	2'	4'	2'	3"	16	3' 6"	5' 0"	4' 6"	1,000	12.0	40 / 20
252	B	2'	5'	2'	3"	20	3' 6"	6' 0"	4' 6"	1,100	14.7	50 / 25
322	C	3'	2'	2'	21"	12	5' 0"	4' 6"	2' 10"	750	9.0	30 / 15
322.5	C	3'	2'	2'6"	21"	15	5' 0"	4' 6"	3' 4"	850	12.0	40 / 20
332	C	3'	3'	2'	21"	18	5' 0"	5' 8"	2' 10"	1,100	12.0	40 / 20
332.5	C	3'	3'	2'6"	21"	22.5	5' 0"	5' 8"	3' 4"	1,200	14.7	50 / 25
342	C	3'	4'	2'	21"	24	5' 0"	6' 8"	2' 10"	1,300	14.7	50 / 25
422	C	4'	2'	2'	21"	16	6' 0"	4' 8"	3' 1"	900	12.0	40 / 20
422.5	C	4'	2'	2'6"	21"	20	6' 0"	4' 8"	3' 7"	1,100	14.7	50 / 25
432	C	4'	3'	2'	21"	24	6' 0"	5' 8"	3' 1"	1,200	14.7	50 / 25
432.5	C	4'	3'	2'6"	25"	30	6' 6"	6' 6"	3' 7"	1,400	18.0	60 / 30
442	C	4'	4'	2'	25"	32	6' 6"	7' 6"	3' 1"	1,400	18.0	60 / 30
522	C	5'	2'	2'	21"	20	7' 0"	4' 8"	3' 1"	1,100	14.7	50 / 25
532	C	5'	3'	2'	25"	30	7' 6"	6' 6"	3' 1"	1,300	18.0	60 / 30
532.5	C	5'	3'	2'6"	25"	37.5	7' 6"	6' 6"	3' 7"	1,400	18.0	60 / 30
542	C	5'	4'	2'	25"	40	7' 6"	7' 6"	3' 1"	1,500	18.0	60 / 30

* Dimensions, Weights, and Specifications are Subject to Change without Notice. Contact Factory for Latest Specifications.

Model Number (WHD)	CIRCULATION*			EXHAUST*	
	Rate. (CFM)	Changes / Min.	Motor (HP)	Exhaust (CFM)	Motor (HP)
222	350	43.7	1/3	50	1/45
232	350	29.2	1/3	50	1/45
242	700	43.7	1/3	100	1/20
252	700	35.0	1/3	100	1/20
322	350	29.1	1/3	50	1/45
322.5	350	23.3	1/3	50	1/45
332	700	38.8	1/3	100	1/20
332.5	700	31.0	1/3	100	1/20
342	700	29.0	1/3	100	1/20
422	700	43.7	1/3	100	1/20
422.5	700	35.0	1/3	100	1/20
432	700	29.0	1/3	100	1/20
432.5	1,400	46.6	3/4	250	1/3
442	1,400	43.7	3/4	250	1/3
522	700	35.0	1/3	100	1/20
532	1,400	46.6	3/4	250	1/3
532.5	1,400	37.2	3/4	250	1/3
542	1,400	35.0	3/4	250	1/3

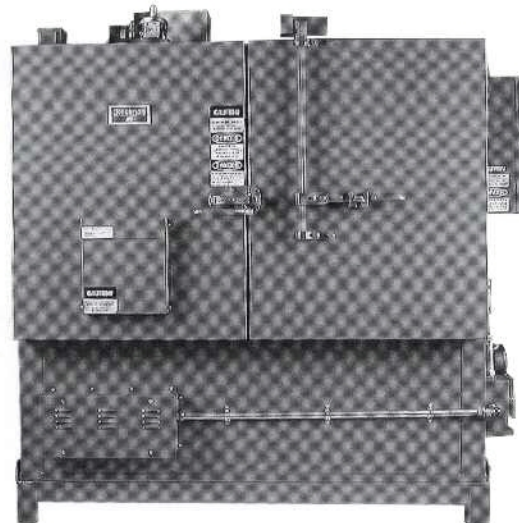

* Specifications are Subject to Change without Notice. Contact Factory for Latest Specifications.

Model Number (WHD)	Optional Drip Pan & Loading Rack*			Optional Removable Shelves*			Optional Oven Stand*								
	(W x H x D)			(W x H x D)			(W x H x D)								
222	1' 11"	x	1"	x	1' 11"	1' 11"	x	1"	x	1' 11"	3' 0"	x	2' 6"	x	2' 9"
232	1' 11"	x	1"	x	1' 11"	1' 11"	x	1"	x	1' 11"	3' 0"	x	2' 0"	x	2' 9"
242	1' 11"	x	1"	x	1' 11"	1' 11"	x	1"	x	1' 11"	3' 0"	x	1' 0"	x	3' 3"
252	1' 11"	x	1"	x	1' 11"	1' 11"	x	1"	x	1' 11"	3' 0"	x	0' 6"	x	3' 3"
322	2' 11"	x	1.5"	x	1' 11"	2' 11"	x	1.5"	x	1' 11"	4' 3"	x	1' 2"	x	2' 3"
322.5	2' 11"	x	1.5"	x	2' 5"	2' 11"	x	1.5"	x	2' 5"	4' 3"	x	1' 2"	x	2' 9"
332	2' 11"	x	1.5"	x	1' 11"	2' 11"	x	1.5"	x	1' 11"	4' 3"	x	0' 6"	x	2' 3"
332.5	2' 11"	x	1.5"	x	2' 5"	2' 11"	x	1.5"	x	2' 5"	4' 3"	x	0' 6"	x	2' 9"
342	2' 11"	x	1.5"	x	1' 11"	2' 11"	x	1.5"	x	1' 11"	N/A				
422	3' 11"	x	1.5"	x	1' 11"	3' 11"	x	1.5"	x	1' 11"	5' 3"	x	1' 2"	x	2' 6"
422.5	3' 11"	x	1.5"	x	2' 5"	3' 11"	x	1.5"	x	2' 5"	5' 3"	x	1' 2"	x	3' 0"
432	3' 11"	x	1.5"	x	1' 11"	3' 11"	x	1.5"	x	1' 11"	5' 3"	x	0' 6"	x	2' 6"
432.5	3' 11"	x	1.5"	x	2' 5"	3' 11"	x	1.5"	x	2' 5"	N/A				
442	3' 11"	x	1.5"	x	1' 11"	3' 11"	x	1.5"	x	1' 11"	N/A				
522	4' 11"	x	1.5"	x	1' 11"	4' 11"	x	1.5"	x	1' 11"	6' 3"	x	1' 2"	x	2' 6"
532	4' 11"	x	1.5"	x	1' 11"	4' 11"	x	1.5"	x	1' 11"	N/A				
532.5	4' 11"	x	1.5"	x	2' 5"	4' 11"	x	1.5"	x	2' 5"	N/A				
542	4' 11"	x	1.5"	x	1' 11"	4' 11"	x	1.5"	x	1' 11"	N/A				

* Dimensions are Subject to Change without Notice. Contact Factory for Latest Specifications.

OPTIONS

LIMITED WARRANTY

Steelman warrants products to be free from defects in material and workmanship when leaving the factory; provided, however, that liability under this warranty is limited to repairing or replacing (without charge) any defective component within one year from the date of shipment; provided further that in no event shall Steelman be liable for consequential or other damages. Labor charges for the removal or replacement of defective parts are not allowed. No other representation or warranty, either expressed or implied, is made.

HOW TO ORDER

Steelman Industries, Inc. invites your inquiries and special needs. We are prepared to answer your questions and to work with you, either directly from our factory or through our national distributors.

The applications today requiring our expertise seem endless. Does your application require electric or direct firing convection heat? If it does and you also demand quality and value, Steelman will be your choice. Don't be deterred if your size and/or special needs are not addressed in the catalog. Together we will custom design an oven to fit your needs.

Inform us of your application and production requirements via telephone call, fax, mail or email. If your needs are within our expertise, we will immediately return a quote to your attention. If your needs are outside of our abilities, we will immediately inform you.

We welcome your request for quote regardless of whether it is standard from the catalog or not. We normally prepare a formal quote the same day as your request.

We look forward to hearing from you and becoming part of your operation.



STEELMAN INDUSTRIES, INC

Phone: 903-984-3061 • Fax: 903-984-1384
sales@steelman.com • www.steelman.com

Steelman Industries ...

Manufacturing dependable and efficient products for over 40 years.

H-A-S PHASE CONVERTORS

Steelman H-A-S convertors are the most efficient and reliable convertors on the market. Operate three phase motors on single phase service (230/460V) at 100% motor nameplate horsepower. The H-A-S Static is designed for single motor installations and the H-A-S Rotary is designed for multi-motor installations.

BURN-OFF OVENS

(HEAT CLEANING)

They are fully automatic and incorporate unique Top/Down heating. Built standard to FM specifications, they are safe, quick and durable. Uses include but are not limited to stripping coatings, varnishes, plastics, oils, adhesives, etc. Steelman burn-off ovens operate on natural gas or LP gas service.

KVAR POWER FACTOR

CAPACITORS

Steelman KVAR units can eliminate the penalty. Power Factor Capacitors provide big savings to industrial plants, hospitals, oil fields, hi-rise facilities, and other large users of electricity. Save on utility cost. Remove the PF penalty and/or qualify for PF discounts. In addition, reduce line current and improve system voltage.

H-A-S STATIC CONVERTOR



CART LOADING

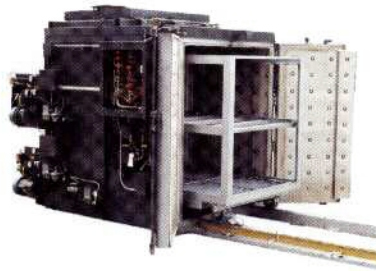

FIXED KVAR UNITS



H-A-S ROTARY CONVERTOR



CUSTOM APPLICATIONS



VAR MANAGER



STEELMAN INDUSTRIES, INC

P.O. BOX 1461 • 2800 HWY 135 N. • KILGORE, TEXAS 75662

PHONE: (903) 984-3061 TOLL FREE: 1-888-735-8831 FAX: (903) 984-1384

WEBSITE: www.steelman.com EMAIL: sales@steelman.com

Printed in USA
REV. 5/04
PB0398